

Gate valve surface box

D400 - extreme traffic load



Code	KVS02
Material	Cast iron
Weight	12 kg
Norm	EN124-2
Package	60 ks/pal
Load class	Extreme traffic load

Gate valve self-leveling box D400, with hinge, KASI PUR damping insert

COVER:

- | Integrated KASI-PUR damping insert with high resistance
- | Hinge secured with pin preventing removal from frame
- | Optional your own design/logo

FRAME:

- | Suitable for places with extreme traffic loads
- | Self-levelling frame for best quality
- | Two parts design with PUR seal
- | Adjustable construction height 200-290 mm

OTHER:

- | Comes with black powder coating
- | For any fixed surface boxes
- | Available installation toolings
- | Store separately in two parts

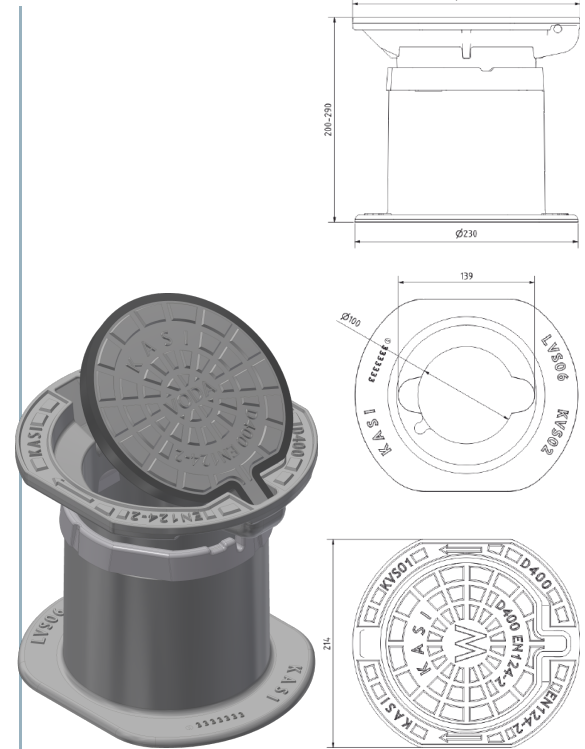

CUSTOM SOLUTIONS



DAMPING INSERT



MAX. OPENING ANGLE

